

# CANARE™

## Coaxial Cable Stripper TS100 (C/E/U)

### Instruction Manual

Thank you for purchasing the Canare TS100E/U Coaxial Cable Stripper. Please carefully read all information for proper usage and safe operation of this professional hand tool. We suggest you keep these instructions in a convenient location for future reference.

**Note:**  
Prior to shipping, Canare tests, adjusts and presets the blade height of every stripper tool. Any cable scrap remaining inside the new housing is perfectly normal and is your assurance of Canare's ongoing commitment to quality.

MO49 [2018.4] Canare Corporation of America. All rights reserved. Printed in Japan

## Safety Precautions

- The Canare TS100E/U has been exclusively designed for 3-Step precision stripping of coaxial cable and should only be used on the designated cable types/models specified in this manual.
- Improper use of this device can cause severe cuts to hands & fingers.
- Do not use this tool to cut, prep or strip any other cable types (i.e. twisted pair, UTP, Star Quad, etc.)
- This tool will only accommodate coaxial cables with an outside diameter range of  $\phi 4\text{mm} \sim \phi 11\text{mm}$ .

### Never allow children to touch, handle or play with this tool

The TS100E/U houses three (3) razor sharp circular blades, plus one (1) straight edge and can cause serious injury if mishandled.

### Do not allow fingers or foreign objects to probe inside of this tool

Blades may not always be easily visible. Please exercise caution during normal operating procedures and especially when replacing the modular blade cartridges.

### Do not disassemble, reconstruct or attempt any repair of this tool

Damage to device or personal injury can result.

## Features

### Combination Circular Blades and Straight Edge

Three (3) internal circular steel blades perform precise, extremely clean 3-step cuts and feature a unique self-cleaning action. One (1) laterally mounted straight edge blade side-slits the cable jacket for easy peel off. All blade heights can be adjusted using the supplied Hex (1.5mm) L wrench.

### Replaceable Circular Blade Cassettes

Pop out, snap in Blade Cassettes are cost effective and allow quick and simple tool maintenance.

### 5 Different Cable Pre-Sets

Rotate knob to select from factory adjusted cable setups, or create your own favorite individual coax model presets.

### Cable Handle Grip with V-Guide

Special knurled hand grip with spring loaded action, automatically clamps down around cable upon insertion to prevent shift and twist during cutting operations. Adjustable V-Guide rail properly aligns cable within cutting chamber axis point.

### Easy to Use

Ergonomic design reduces hand/wrist/finger fatigue and promotes stable, consistent stripping results.

### Multi-Function Adjustment Wrench

A high quality Hex L Wrench (1.5mm) is included with a built-in storage holder conveniently located on the tool lid top.

## Components

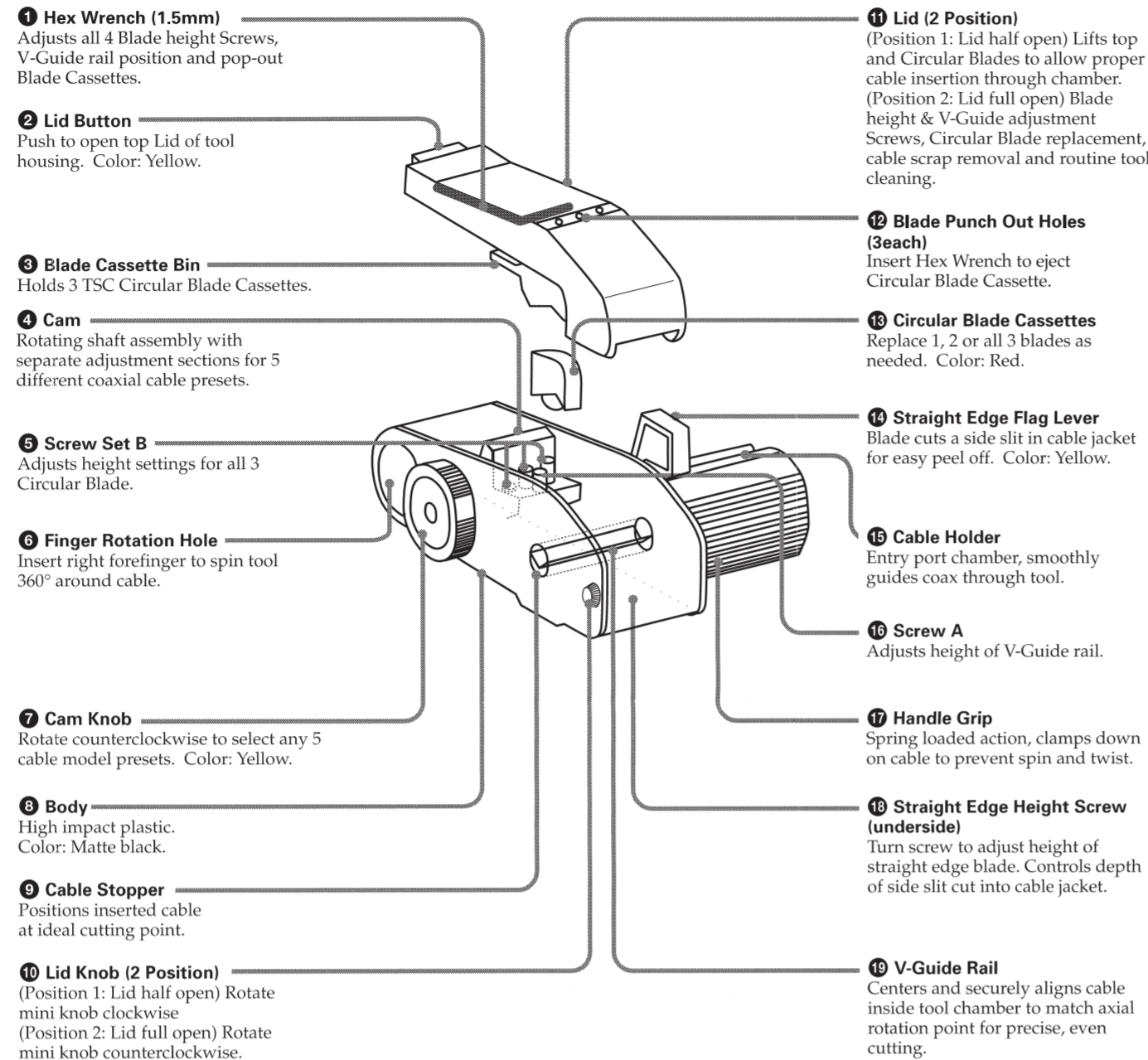

## Operating Tips

### Blades no longer cut cleanly

One or more of the circular blades may be dull, nicked or worn out. If stripper cuts poorly, replace one or all of the old blades as needed. Read the section: "Replacing Circular Blade Cassette" in this manual.

### For clean and accurate strips

Rotate tool slowly! The TS100E/U strips by cutting 360° around the cable. If you rotate the tool too quickly, the blades may shift and miss the axial cut location causing uneven results.

### Prep cable before insertion

Always make a clean, perfectly square right angle blunt cut at the end of coax using a high quality wire cutter.

### Perfect 3-Step strip dimensions

Insert coax smoothly into handle grip. Push all the way through the V-Guide chamber until cable hits final stop point. After stripping, compare finished cut lengths with the cable reference diagram shown on lid label.

## TS100E/U Mechanical Specifications

### External Dimensions:

126 × 99.4 × 61.1mm (W/D/H)  
Weight: Approx. 200g / 0.4 lbs (270g / 0.6 lbs with package)  
Cable Chamber OD:  $\phi 4\text{mm} - 11\text{mm}$

### Lifetime of Blades:

≥ 1,000 cuts (LV-61S)

### Recommended Tool Rotating Speed:

1 - 2 times per second

Body: Polyamide, Polyacetal

Blades: Hardened Steel

Metal Parts: Stainless Steel, Spring Wire, Brass, Aluminum

Attachments: Hex Wrench (1.5mm), Tsc (Replaceable blade)

Blank Labels for Cam-knob (5), Instruction Manual

### Note:

Cut results may vary due to cable size tolerance in jacket material, insulation properties, copper quality, ambient temperature, etc.

## Q&A

### I cannot get a clean cut around the braid shield, foil or jacket... Tool is cutting too deeply into the inner/outer conductors.

- Verify Cam-knob selection with cable (label) type in use.
- Increase the number of finger rotations (10-20 turns).
- Adjust individual Blade height settings.
- Adjust V-Guide height for centering cable inside tool.
- Check for dull, nicked or broken circular blades. Use recommended lubricant spray or replace the blade cassette(s) as needed.

### The side slit jacket cut is too shallow/deep

- Depress Straight Edge Flag Lever firmly and continue to hold down while pulling out cut cable.
- If side slit cut is too shallow, turn the hex screw (located on tool bottom) counterclockwise, if too deep, turn clockwise. (0.5mm per revolution)  
Note: Straight edge is factory preset to a cut depth of 0.8mm.

### Jacket scrap or copper strands get stuck inside tool

- Turn mini Lid Knob to full open position, raise top and tap out cable refuse.

### WARNING!

Use a tweezers to remove any lodged cable scrap. DO NOT USE YOUR FINGERS!

## NOTICE

### Adjust Blade Height.

Please pay attention as follows before turning screws.

**Stop screwing, when the bottom of the screw hits the head of the screw in the next position (★on the picture), or when the head of screw touches the surface of the CAM**

### Some part may be destroyed by forcing the screws.

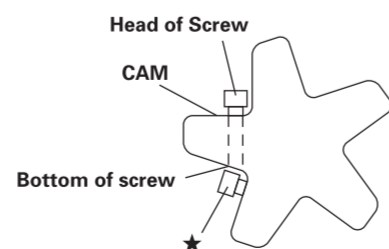

## Cutting Coaxial Cable (LV-61S)

The following is explanation on how to cut and strip coaxial cable using Canare's flexible LV-61S (RG59B/U) as an example. For other models, please read: "Tool set up for stripping other type cable."

Before proceeding, make a clean, perfectly straight right angle blunt cut at the end of coax.



### WARNING!

3 circular blades are exposed when lid is in full open position. Keep hands & fingers away from blades. Always retighten Lid Knob to half open position after cleaning.

### 1 Push Yellow Lid Button ② to half open tool top.

### 2 Turn Yellow Cam Knob ⑦ to select "LV-61S." (Label should be positioned at 12 O'clock)

### 3 Insert cable into Handle Grip and push completely through chamber V-Guide ⑩ until coax comes to a forced stop.

### 4 Push down lid ⑪ with right thumb and snap lock top back into body.

### 5 With left hand, firmly grasp Handle Grip ⑬ and slowly rotate tool 7 - 10 times in a forward direction. Push Yellow Lid Button with right thumb to half open tool.

### 6 Reposition tool in left hand as shown.

### 7 Using left thumb, firmly depress and hold down Yellow Flag Lever ⑭ while pulling cable straight out with right hand.

### 8 Twist & pull off cut insulation, remove shield scrap, and peel off jacket.

### 9 Unscrew mini Lid Knob to half or full open position. Shake, tap or blow out cable scrap from inside tool body.

### WARNING!

Use a tweezers to remove any lodged cable scrap. DO NOT USE YOUR FINGERS!

Clean out cable scraps

## Cable Model Selection & Set Up

### Factory Pre-sets

Prior to shipping, the TS100E/U was adjusted and set up for stripping five (5) different coaxial cable models as indicated on the Cam-knob labels. For detailed specifications on individual cable dimensions, please refer to the "Coaxial Cable Size Table" in this manual.

### Tool set up for stripping other type cable

For creating new cable presets: First determine the OD of cable jacket, outer conductor, insulator and inner conductor. Then reference the "Coaxial Cable Size Table" below for TS100E/U set up adjustments

### WARNING!

Very sharp blades are exposed when adjusting cut depth. Always keep hands & fingers away from internal blades.

### 1 Peel off label from Cam Knob for an unused cable model. On a fresh label (packaged with this tool), print the new cable model/type and apply sticker to Cam-knob ⑦.

### 2 Turn Lid Knob ⑩ and raise top to full open position.

### 3 Choose the closest cable size from the table below, Adjust Screw A ⑬ (V-Guide height) with attached Hex Wrench ①.

(Note: For each factory preset, Screw A height was adjusted 0.2mm-0.5mm greater than the screw height figures shown in "Coaxial Cable Size Table" below. This adjustment compensates for compression of cable during cutting process.)

Hint: For easier access to measure screw height with a straight edge ruler, rotate the Cam-Knob counterclockwise 1 position.

### 4 Adjust Screw Set B ⑮ following specification table below. (For example, if OD of inner conductor is $\phi 0.8\text{mm}$ , the height of far right Screw is 2mm.)

### 5 Reposition the Cam Knob selector to newly created cable setup and do a test cut. If poor strip results, repeat steps 3 and 4 above and readjust Screw A and Screw Set B.

### Coaxial Cable Size Table

Coaxial Cable	Jacket OD	Cable Size/Height of Screw (Unit:mm)						
		Screw A	Screw B	Insulator OD	Screw B MS5B	Inner Cond. OD	Screw B Right	
V*3C series	4.4	9.0	3.7	4.4	3.1	3.4	0.54	1.5
L-2SCHD	4.0	9.0	3.0	3.9	2.4	2.6	0.5	0.9
185A	4.0	9.0	3.2	3.9	2.99	2.0	0.38	0.9
V*4CFB series	5.0	8.4	4.4	4.4	3.7	3.2	0.8	1.0
150A	5.0	8.4	4.3	4.4	3.4	2.6	0.81	1.0
3C2V/L3C2V	5.4	8.0	3.8	4.9	3.1	3.4	0.5	1.5
L-K2V5	5.5	8.0	3.6	4.9	3.1	3.4	0.54	1.5
L-3CFB	5.5	8.0	3.8	4.9	3.1	3.4	0.65	1.5
L-3CUHD	5.5	8.0	3.9	5.0	3.3	3.4	0.75	1.6
LV60S	6.1	7.4	4.1	5.3	3.6	3.6	0.6	1.8
L-KCFB	6.1	7.4	4.4	5.2	3.7	3.5	0.8	2.0
V*3C series	6.0	7.5	5.3	6.0	4.8	5.1	0.78	2.0
801/804F	6.1	7.6	4.4	5.5	3.7	3.4	0.50/0.76	2.0
150A	5.9	7.6	4.4	5.5	3.7	3.4	0.81	1.6
169A	5.9	7.6	5.2	5.5	4.3	3.4	1.02	1.6
169A	7.0	6.5	5.3	5.7	4.6	3.7	1.02	1.6
L-4SCHD+	7.0	6.5	5.3	5.7	4.57	3.9	1.02	1.3
V*5CFB series	6.5	7.0	5.7	6.4	5.0	4.7	1.05	2.2
L-KCFB	7.7	5.8	5.7	6.8	5.0	4.0	1.05	2.4
LV-775	7.7	5.8	5.9	6.8	4.8	4.0	0.78	2.6
801/804F	7.7	5.8	6.5	7.0	5.0/4.9	4.0	0.79	2.6
7C/FB/L7CFB	10.2	3.3	8.2	10.2	7.3	7.7	1.5	3.2
9292/7731A	10.3/10.2	3.3	8.1	10.4	7.1	7.5	1.63	3.8
CS-6	5.8	7.7	3.8	5.2	3.0	3.6	1.3	1.5

### Note:

- Coaxial cable tolerances may vary. We recommend a test cut to confirm proper set up of all blade heights.
- Contact Canare for the screw height settings of coaxial cables not listed in the above table.
- The following types of cables may not be accurately processed by Canare's TS100E/U Cable Stripper, owing to their construction.
  - Cables employing such hard jacket material as polyethylene.
  - Cables employing such particularly soft insulator material as high-foam polyethylene.
  - Cables employing steel wire and semirigid pipe for outer conductor.

**CANARE ELECTRIC CO., LTD**  
<http://www.canare.co.jp/>

## Tips for Better Stripping

### Adjust Blade Height & V-Guide

If you cannot achieve good clean consistent cable strips, try the following adjustments:

### WARNING!

Very sharp blades are exposed when adjusting cut depth. Always keep hands & fingers away from internal blades.

### 1 Loosen Lid Knob ⑩ and raise top to full open position.

### 2 Adjust height of Screw A ⑬ and Screw Set B ⑮ with attached Hex Wrench ①.

**Screw A:** V-Guide ⑩ height adjustment. To lower rail turn Screw A right, to raise rail turn Screw A left.

Hint: Center of Coax must be in aligned with the rotation axis point of cable insertion chamber.

**Screw Set B:** Circular Blade depth cut adjustment. For deeper cut turn Screw(s) right; shallower turn Screw(s) left.

Hint: For easier straight edge ruler access to measure screw height, slightly rotate the Cam Knob.

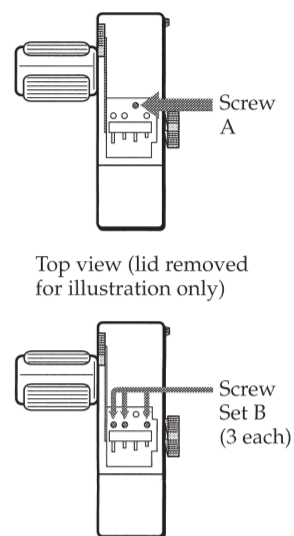

### ADJUSTING SCREW HEIGHT

- Use a small metric straight edge ruler to measure screw height.
- Screw height is adjusted in approx. 0.5 mm increments for every 360° rotation.

For example: To adjust screw height to 4.3 mm  
**1** Using straight edge as a guide, adjust screw to a height of approx. 4.5 mm.  
**2** Turn screw 180° clockwise (.25 mm).  
**3** Confirm screw height of approx. 4.3 mm.

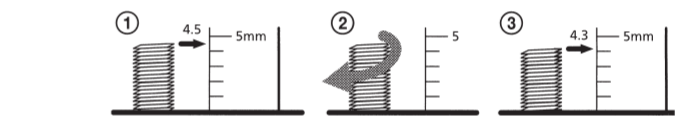

- Do test-cut to verify blade setting.

### 3 Adjust jacket side slit Straight Edge Blade (screw located on the underside of tool ⑮).

For deeper cut turn screw left; for shallower cut turn screw right.

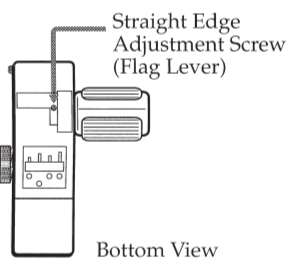

### 4 Close Lid ⑪ then tighten Lid knob ⑩.

### Replacing Circular Blade Cassette(s)

When circular blades becomes dull, nicked or broken, replace with Canare Model: TSC Blade Cassettes.

### WARNING!

Very sharp blades are exposed when replacing Blade Cassettes. Always keep hands & fingers away from internal blades.

### 1 Loosen Lid Knob ⑩ and raise Lid ⑪ top to full open position.

### 2 Insert one end of Hex Wrench ① (included) into Blade Punch Out Hole ⑫ and eject used Cassette ⑬.

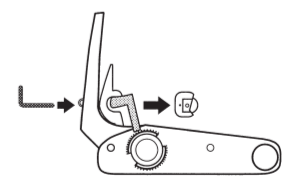

### 3 Snap lock new Cassette Blade into place.

**CAUTION:** Use only the special Insertion Clip (included) to grasp and maneuver cartridge into position. DO NOT USE YOUR FINGERS!

Hint: Please note correct orientation of Blade Cassette before installing.

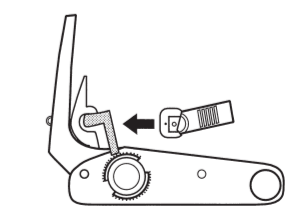

### 4 After replacing Blade(s), close Lid ⑪ then tighten Lid Knob ⑩.