

Optical to Electric Converter Model OE3G-101



MAW135E V6.0

Safety Precautions

Instruction Manual

Use of controls or adjustments or performances other than those specified herein may result in hazardous radiation exposure.

CAUTION

- Do not block the vents. The blocking raises an internal temperature and may cause damages.
- Ensure that the dust caps are attached to LC connector and BNC connector for each when not in use.

General Description

- An optical to electric converter for 3G-SDI, HD-SDI, SD-SDI and DVB-ASI (multi rate, multi format) video transmission
- Cable driver and re-clocker equipped
- Available to receive wavelength from 1200nm to 1620nm
- Available to support pathological pattern (SMPTE RP178-2004, RP198-1998)
- Installation to Canare's plug-in platforms available.

Outline & Functions

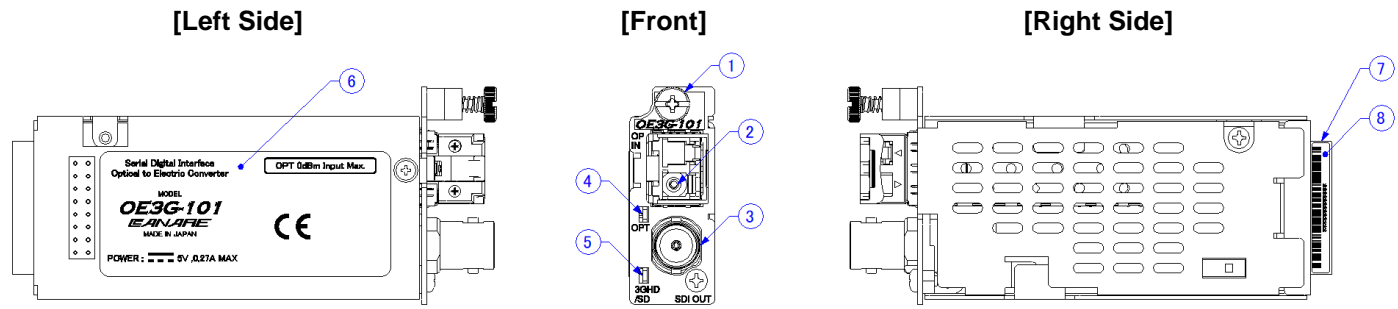

1) Captive Screw	To fix this product to the platform.
2) LC Connector	For connection with SM optical fiber.
3) BNC Connector	For connection with 75Ω coaxial cable to output the signal.
4) Status LED (OPT)	Lights up in Green when optical signal is being received.
5) Status LED (3GHD/SD)	Lights up in Green when 3G-SDI or HD-SDI signal is input. Lights up in Yellow when SD-SDI or DVB-ASI with 270Mbps signal is input.
6) ID Label	Describes the model name, rating, certifications, and so on
7) DIN Connector (16-pin)	For the power supply and status signal outputs.
8) Connector Label	Production No. described.

Mounting the Converter in the Power Unit

1. Install this product into the mounting slot of the platform* by gripping the captive screw as shown in Figure 1.
Note: platform*: 6PSC, 161UPSC
2. Align the captive screw to correspond to the screw hole in the platform, and tighten securely with a philips head screw driver to secure this product.
3. Connect coaxial cable to this product's BNC connector.
4. Connect optical fiber to this product's LC connector.



Figure.1 OE converter installation

Note) Be sure to keep the ferrule tip of the plug and the internal of LC connector clean as shown in Figure 2.
If a fiber-optic connector becomes dirty, the lighting output loss may be increased.

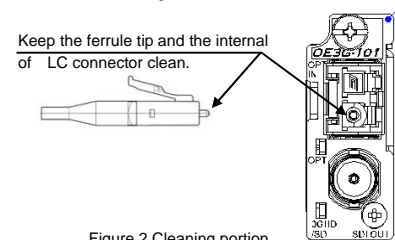

Figure.2 Cleaning portion

Specifications

Transmission Rate with re-clocking	3G-SDI : 2.97Gbps, 2.97/1.001Gbps HD-SDI : 1.485Gbps, 1.485/1.001Gbps SD-SDI : 270Mbps DVB-ASI : 270Mbps	EMC	: FCC part15 Subpart B : EN55032 : EN55024 : EN55035
Light Reception Wavelength	: 1260nm to 1650nm	Operating Temperature	: 0°C to 40°C (no condensation)
Optical Fiber	: 1-core single mode	Storage Temperature	: -40°C to 85°C
Fiber-Optic Connector	: LC type	Power Source	: +5VDC ±0.5V
Minimum Light Reception Level	: -23.0dBm@1.485Gbps : -22.0dBm@2.97Gbps	Power Consumption	: Max. 1.35W
Overload Optical Power	: 0dBm	Weight	: Approx. 100g
Device Damaging Optical Power	: +5dBm	Dimensions	: 78.4mm(D) × 43.4mm (H) × 17mm (W) (excluding connectors)
		Accessories	: Fiber-optic adapter dust cap 1 : BNC receptacle dust cap 1

The exterior features and specifications in this document are subject to change due to modification without prior notice.